

**KLÜBER**  
LUBRICATION

## Driving with Klüber

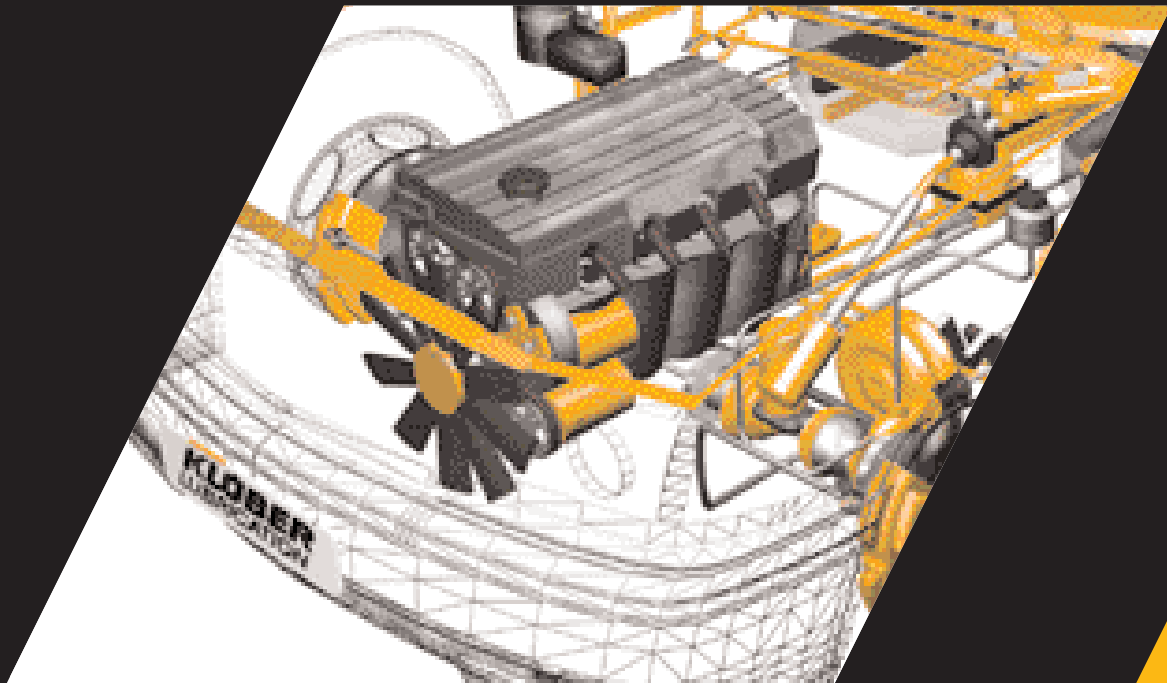

... your partner for innovative lubricants

**Lubrication is our World**

# Contents

## **Klüber Lubricants**

**Innovative concepts, excellent prospects** 4

### **For vehicle components**

**Brakes** 6

**Steering systems** 8

**Axles and constant velocity joints** 9

**Engine and additional components** 10

**Gearshift** 11

**Clutch** 12

**Electrics and passenger compartment** 13

**Locks and hinges** 14

**Window lifters and sun roofs** 15

**Seats and seat belts** 16

**Bonded coatings for profiled seals** 17

**Test rigs** 18

**Dry lubrication** 20

**Containers and packing units** 21

## **Klüber companies and production sites**

**Klüber – all over the world** 22

# Your visions are what drives us

There was a time when the antilock braking system was considered a new milestone in the development of motor vehicles; today it is a piece of standard equipment. What was highly innovative yesterday is now a series product. As markets are becoming tighter, it is not enough to make do with the standards we are used to. New ideas are called for, leading us towards better quality, economy, environmental protection and service.

These are the requirements we have to meet if we want to be successful in the increasing competition for market share.

As manufacturers of special lubricants for the automotive sector and its suppliers, we are very close to your field of activities. We know your needs and your visions, and their importance for success in the long term.

More than 75 years of experience and a team of highly qualified experts put us in a position to create products that live up to the ever more stringent requirements of automobile construction.

No matter what challenge you have laid out for us, we are ready to tackle it and offer a solution that is tailored to your needs and wishes. If requested, we will develop a lubricant specifically to suit your individual requirements.

Klüber is your partner whenever a tribology specialist is needed.

This brochure will tell you about our innovative lubricants for all kinds of automotive applications that are already available today.

## Klüber lubricants pave the road to success

From constant velocity joints to central locking – there is hardly a part of a modern-day vehicle that will function correctly without the right lubricant. But not just any lubricant: higher performance requirements, more convenience, better environmental protection – our specialists will not rest until they have found the optimum economic lubrication solution to cover all aspects.

We understand lubricants to be design elements that help to save time and capital, which opens up entirely new marketing potential for you. Use our know-how and make it home first with your customer: “Simultaneous Engineering” is the most direct road to success.

### All revved up for quality

Whether you are moving by road, rail, sea or air: all means of transport make use of highly complex technical systems where operational reliability is rated top priority. And since lubricants play a decisive role in the pursuit of this goal, Klüber has adopted an exemplary policy for enhancing quality.

The most advanced testing techniques and high quality awareness demonstrate Klüber's commitment to high performance and reliability. And to prove there is more to this than just words we provide certification in accordance with the standards ISO 9001, ISO 14 001 and ISO TS 16 949. These certifications not only refer to the ex-

cellent quality of Klüber lubricants and services, but also to the extraordinary quality awareness of the corporate management and the quality assurance system implemented throughout the company.

### Comfort and convenience boost sales

Today, all branches of industry are aware they need to have something to offer beyond technical progress to make a difference in competition. More and more attention is paid to increasing comfort and convenience. Lower noise, reduced vibration and electronic components assisting the driver are all on the agenda.

For such functions lubricants play a decisive role: special low-noise and anti-friction products for use in components like powertrains, additional engine components, driver's seats and window lifters are Klüber's contribution to enhancing comfort and boosting sales figures.

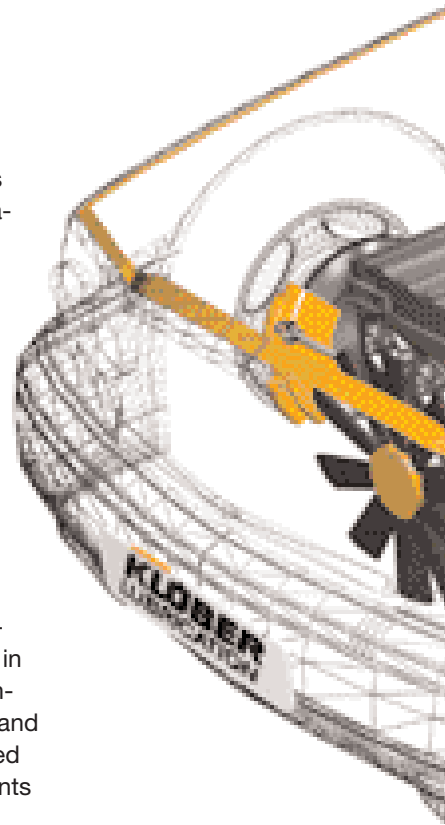

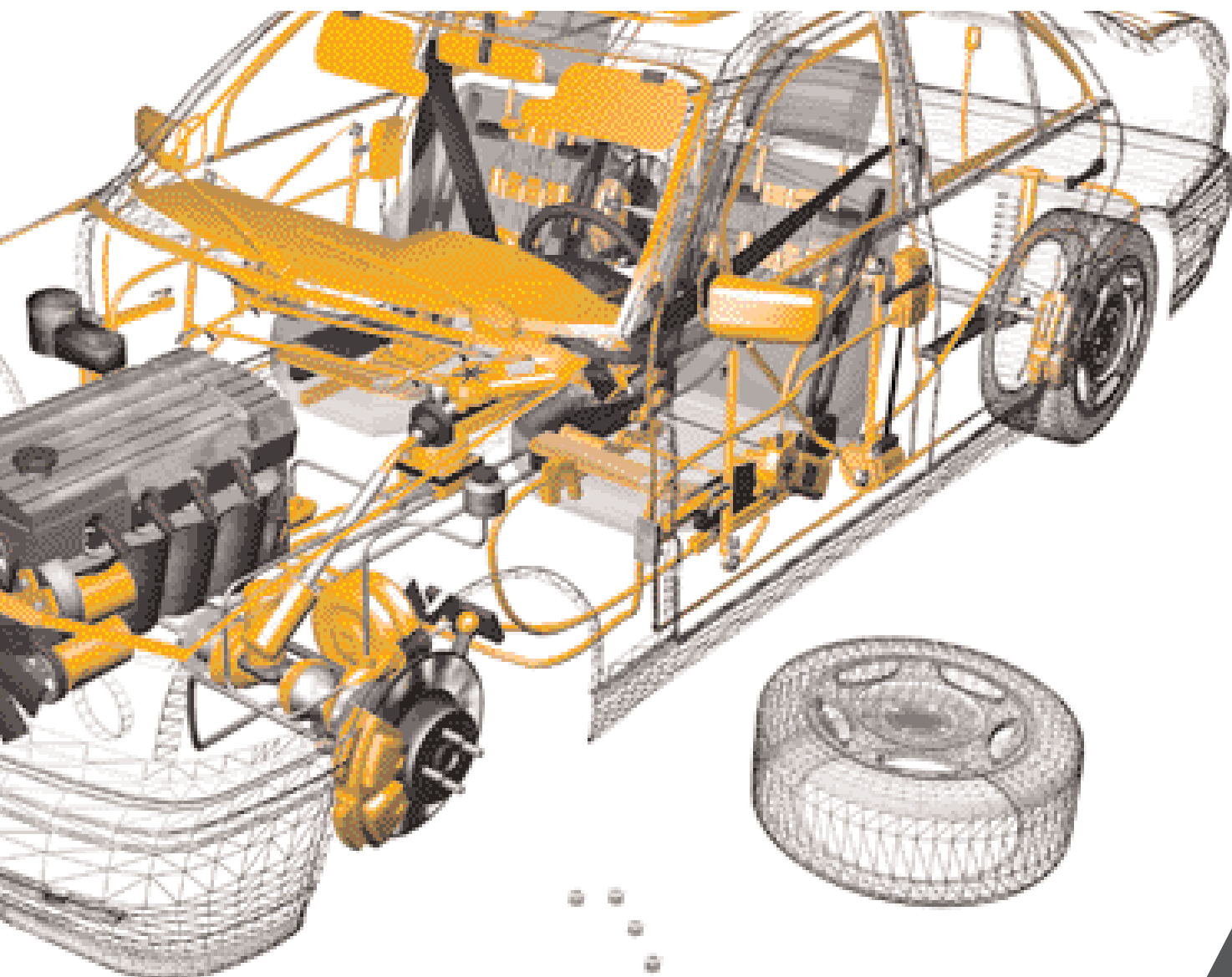

## Commitment to the environment

Minimizing lubricant quantities is beneficial not only economically but also under ecological aspects.

Living up to the requirements of environmental protection is understood by Klüber to be an obligation to the customer as well as to the world we live in. This entails

- the development of high-performance lubricants that ensure lifetime lubrication even in minimum quantities,
- the development of special environmentally friendly, water-based and adhesive dry lubricants and bonded coatings,
- the use of biodegradable raw materials.

It seems that we are on the right track. Accordingly, Klüber received the Environmental Protection Award of the City of Munich and successfully underwent numerous EC eco-audits like DIN ISO 14001 and EMAS in the last few years.

## Brakes

### Components

- Anti-lock braking system (ABS)
- Assembly aids
- Brake booster
- Brake cables
- Disc brakes
- Drum brakes
- Electric brakes
- Master brake cylinders
- Proportioning valves

### Lubricant requirements

- Compatibility with elastomers  
e.g. EPDM, SBR, CR
- Neutral behavior towards plastics
- Wide temperature range
- Good corrosion protection
- Resistance to brake fluids

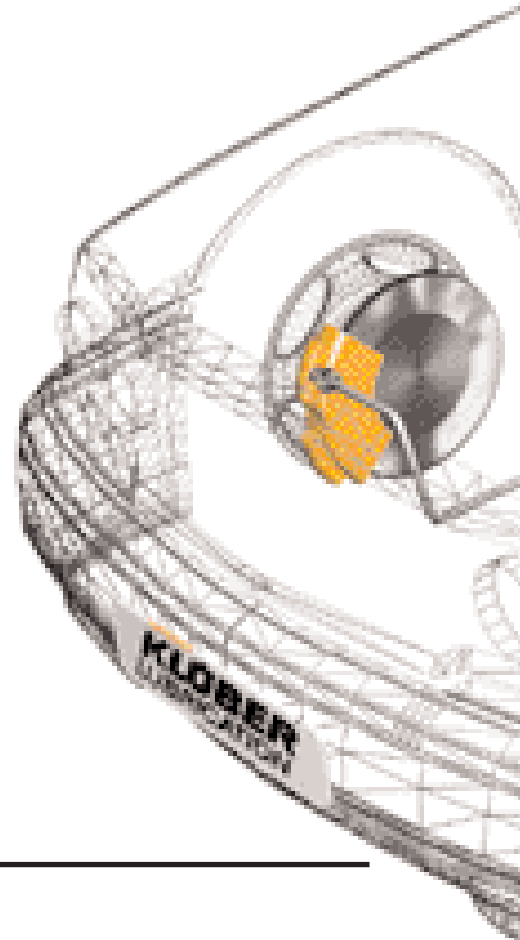

---

### Klüber products

*in alphabetical order*

Klüberfluid 9 R 100, Klüberpaste HEL 46-450, Klübersynth HB 72-52, Klübersynth HLR 46-371, SYNTHESO GLK 0, SYNTHESO GLK 1, SYNTHESO GLK 1 PF, SYNTHESO GLEP 1, UNISILKON GLK 112, UNISILKON GL 301, UNISILKON TKM 1011, WOLFRAKOTE TOP PASTE

### Product approvals / specifications

*in alphabetical order*

Bosch VS 18314-Ft/N 28 FT 1140-002, Brembo D1.04.07.000, DaimlerCrysler MS 9708, Continental-Teves N 55315.03, Ford ESA-M1C194-A, Ford WSA-M1C246-A, GM 9986206, Knorr N 503880, Lucas T.S. 2-32-101, Lucas T.S. 2-33-03, Meritor 2297-N-7164, PBR MS 1120, PBR MS 1124, VW-TL 52150, VW-TL 52112, Wabco JED 294, 785

### Customers

*in alphabetical order*

ADVICS (Aisin-Seiki), BMW, Bosch, Brembo, Continental-Teves, Continental-Teves, Delphi, DaimlerChrysler, Ford, Knorr-Bremse, Meritor, NSK, Opel, PBR, Porsche, Seat, TRW, Wabco, VW

*Please note that the a.m. information is only a small extract from our range of products and applications.*

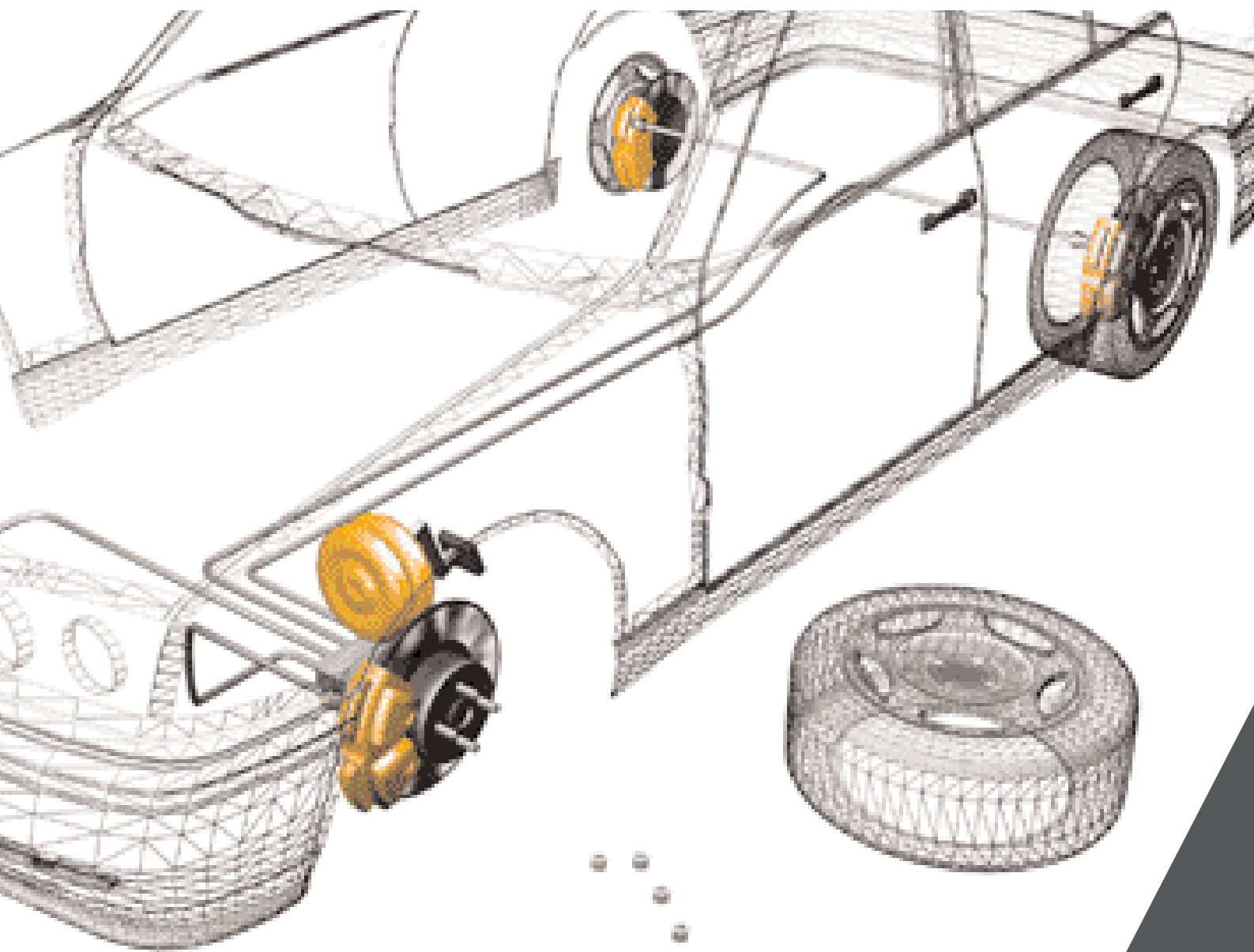

# Steering systems

## Components

Ball joints, electric motors, electric steering systems, seals, small gears, steering gearboxes, steering columns, steering racks

## Lubricant requirements

Low adjusting torques at low temperatures  
Good corrosion protection  
Good dampening properties  
Protection against fretting corrosion

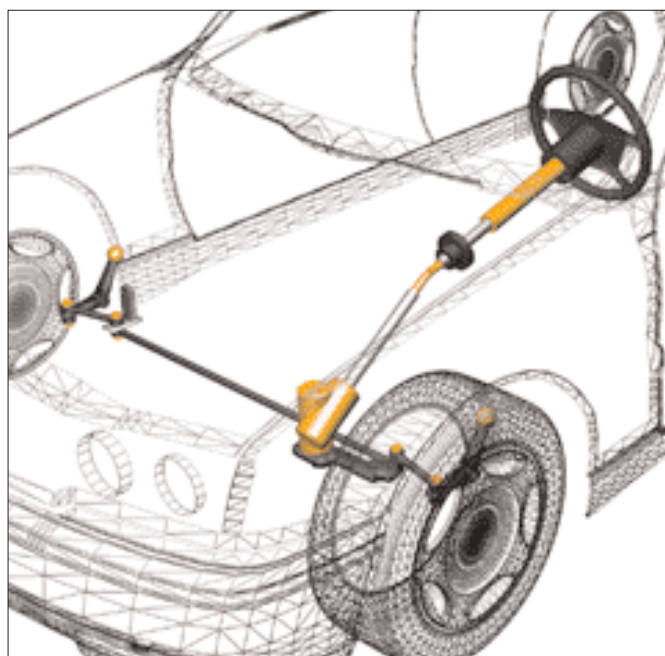

---

## Klüber products

*in alphabetical order*

---

ISOFLEX TOPAS NB 52, ISOFLEX TOPAS NCA 52, ISOFLEX TOPAS NCA 152,  
Klübergrease LFT 71-402, Klüberlub EM 41-92, Klübersynth GE 14-111, Klübersynth LI 44-22,  
Klübersynth LR 44-21, MICROLUBE GLY 92, PROBA 270 ALTEMP P, SYNTHESO GLEP 1,  
SYNTHESO PRO AA 2, UNISILKON TK 002/30.000

## Product approvals / specifications

*in alphabetical order*

DBL 6834.00, Delphi 261 13298, Ford ESF-M99B112-A,  
Ford WSD-M1C234-A2, Porsche 999.917.791.00,  
TRW 62015002, VW-TL 52150, VW-TL 721, VW-TL 778 B,  
ZF-Lemförder LMN 304 B, 304 F und 304 K

## Customers

*in alphabetical order*

DaimlerChrysler, Dana-Nakata, Delphi, General Motors,  
Inauxa, Koyo, Musashi, NSK, Peugeot, Raufoss,  
Thyssen Krupp Presta Steertec, TRW, Visteon, VW,  
ZF-Lemförder, ZF-Lenksysteme

*Please note that the a.m. information is only a small extract from our range of products and applications.*

# Axles and constant velocity joints

## Components

Constant velocity joints  
Seals  
Shock absorbers  
Spline shafts  
Suspensions  
Wheel bearings

## Lubricant requirements

Corrosion protection  
Lifetime lubrication  
Compatibility with elastomers  
Excellent lubricating properties when exposed to oscillation  
Protection against tribocorrosion  
Noise reduction  
Wear protection

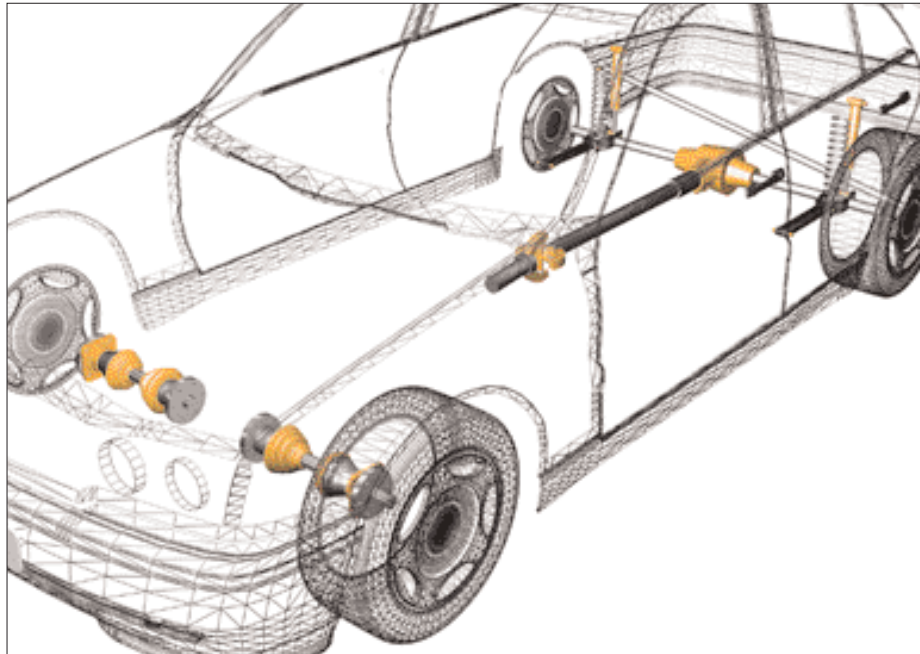

---

## Klüber products

*in alphabetical order*

---

DUOTEMPI PMY 45, ISOFLEX TOPAS NCA 152, ISOFLEX TOPAS NB 52, ISOFLEX TOPAS NB 5051, Klüberlub EH 71-241, Klüberlub EM 41-111, Klüberpaste 46 MR 401, Klüberplex BEM 34-132, POLYLUB GA 352 P, QUIETSCH-EX, SYNTHESO GLEP 1, UNISILKON TK 44 N2

## Product approvals / specifications

*in alphabetical order*

DBL 6827.31, DBL 6817.00, Ford ESA-M1C194-A, Opel B 0400882, Porsche 999.917.791.00, PSA X71 3100, PSA X10 1, VW TL 738, VW TL 751, VW TL 52133, VW TL 52150

## Customers

*in alphabetical order*

Audi, BMW, Delphi, FAG, General Motors, GKN, NSK, Scania, Seat, Valeo, VW

*Please note that the a.m. information is only a small extract from our range of products and applications.*

# Engine and additional components

## Components

Belt tensioner, fuel pump, generator, ignition distributor, injection pump, starter, throttle, valve, turbocharger, water pump, EGR valves, electric contacts, fan bearings, plug connections for fuel and coolants

## Lubricant requirements

Excellent thermal stability  
Maintenance-free  
Low starting torque  
Long-term lubrication  
Material compatibility (e.g. seals, hoses, casings)  
Resistance to ambient media

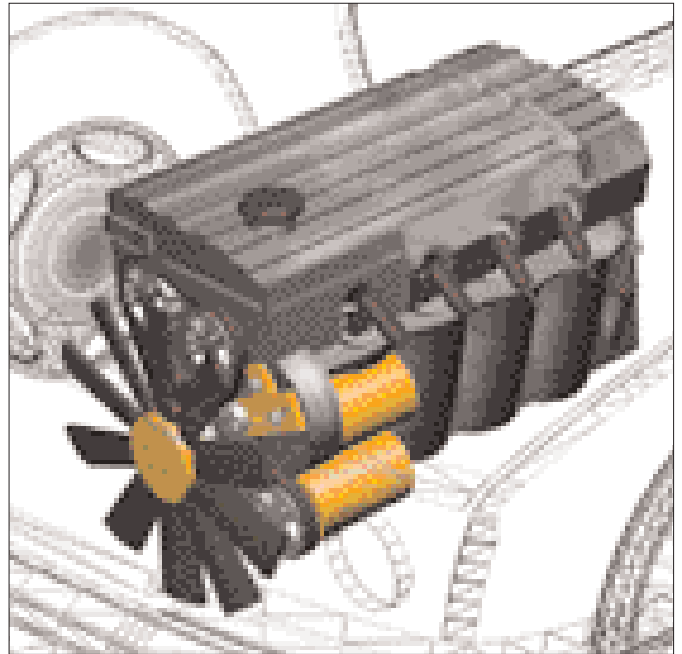

---

## Klüber products

*in alphabetical order*

BARRIERTA-series, EMTEKA NU 15 Extra, ISOFLEX LDS 18 Special A, ISOFLEX TOPAS NCA 52, Klüberalfa DH 3-series, Klüberpaste HEL 46-450, Klübersynth EL 42-32, Klübersynth HB 72-102, Klübersynth LP 42-32, Noxlub KF 1920, PETAMO GHY 133 N, PETAMO GY 193, UNIMOLY HTC Metallic, WOLFRACOAT C

## Product approvals / specifications

*in alphabetical order*

Bosch VS 10832-Ft, Bosch VS 18099-Ft, Bosch FS 18570-Ft, Brembo D1.04.18.000, DBL 6834.00, Ford WSD-M138P8A1, Opel B 0401122, PSA X 71 3134, VW-TL 776, VW-TL 778, VW-TL 52112, VW-TL 52172

## Customers

*in alphabetical order*

Audi, BMW, Bosch, DaimlerChrysler, Delphi, Denso, General Motors, LITENS, Magneti Marelli, Mahle, Siemens VDO, Mazda, PSA, Scania, Toyota, TRW, Visteon, Volvo, VW

*Please note that the a.m. information is only a small extract from our range of products and applications.*

# Gearshift

## Components

Bowden cables  
Gearshifting gate  
Gearshift linkage  
Plain bearing bushes  
Seals

## Lubricant requirements

Lifetime lubrication  
Compatibility with elastomers  
Corrosion protection  
Good dampening properties  
Wide service temperature range

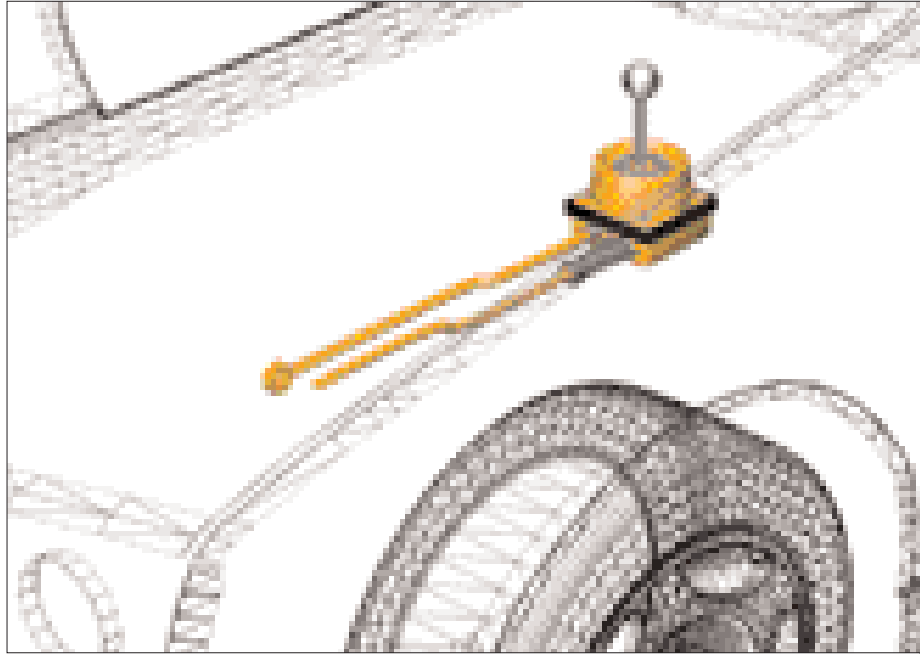

---

## Klüber products

*in alphabetical order*

---

ISOFLEX TOPAS L 32/N, POLYLUB GLY 801, UNISILKON GLK 112

## Product approvals / specifications

*in alphabetical order*

Chrysler MS 9958, Ford ESF-M1C-43-A2,  
Ford WSD-M1C244-A, Opel B 0400571,  
Opel B 0401138, PSA B 71 3841, PSA X 71 3102,  
VW-TL 52147, VW-TL 767X, VW-TL 52142

## Customers

*in alphabetical order*

Audi, BMW, DaimlerChrysler, Dura, Ford,  
Himmermann, Joop, Opel, PSA, Teleflex,  
VW, Woco, ZF

*Please note that the a.m. information is only a small extract from our range of products and applications.*

# Clutch

## Components

Clutch release bearing, master cylinder, slave cylinder, splines, two-mass flywheel

## Lubricant requirements

Protection against tribocorrosion  
Lifetime lubrication  
Elastomer compatibility  
Wide service temperature range  
Good wear protection  
No stick-slip  
Compatibility with brake fluids

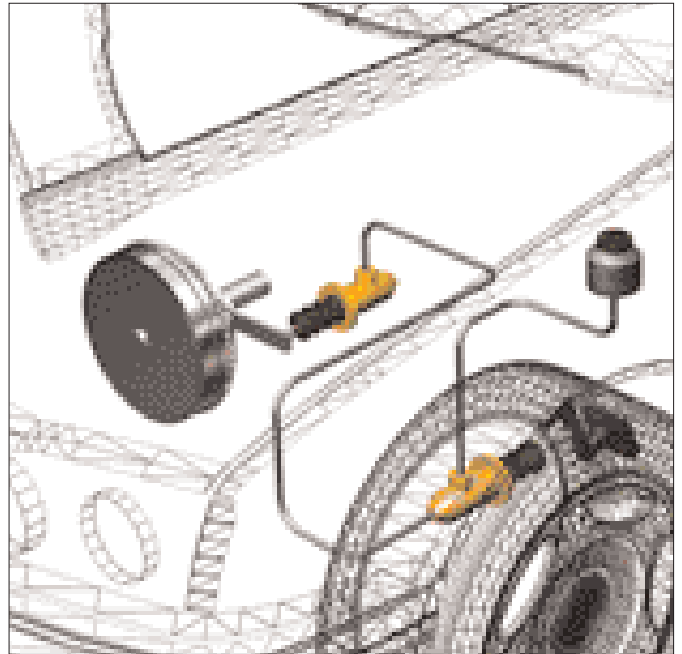

---

## Klüber products

*in alphabetical order*

Klüberalfa HM 83-801, Klübersynth HB 72-102, Klübersynth HLR 46-371, MICROLUBE GL 261, MICROLUBE GNY 202, PETAMO GY 193, SYNTHESO GLK 1, UNISILKON GLK 112, UNISILKON GLK 1301

## Product approvals / specifications

*in alphabetical order*

Ford ESD-M1C220-A, Ford ESF-M1C-43-A2, Opel B 0400043, Opel B 0400571, VW-TL 760, VW-TL 767X

## Customers

*in alphabetical order*

Audi, Automotive Products, BMW, DaimlerChrysler, FAG, Ford, FTE, GAT, INA, Luk, Magneti Marelli, Opel, VALEO, Voith, VW, ZF SACHS

*Please note that the a.m. information is only a small extract from our range of products and applications.*

# Electrics and passenger compartment

## Components

Dashboard  
Electric motors  
Fans  
Heating and cooling systems  
Mirrors  
Small gears  
Sun visor  
Mechanical switches  
Windscreen wipers  
Electrical switches  
Plug-in contacts

## Lubricant requirements

Low breakaway torque at low temperature  
Lifetime lubrication  
Material compatibility  
Wide temperature range  
Good surface adhesion  
Mechanical dampening  
Noise dampening

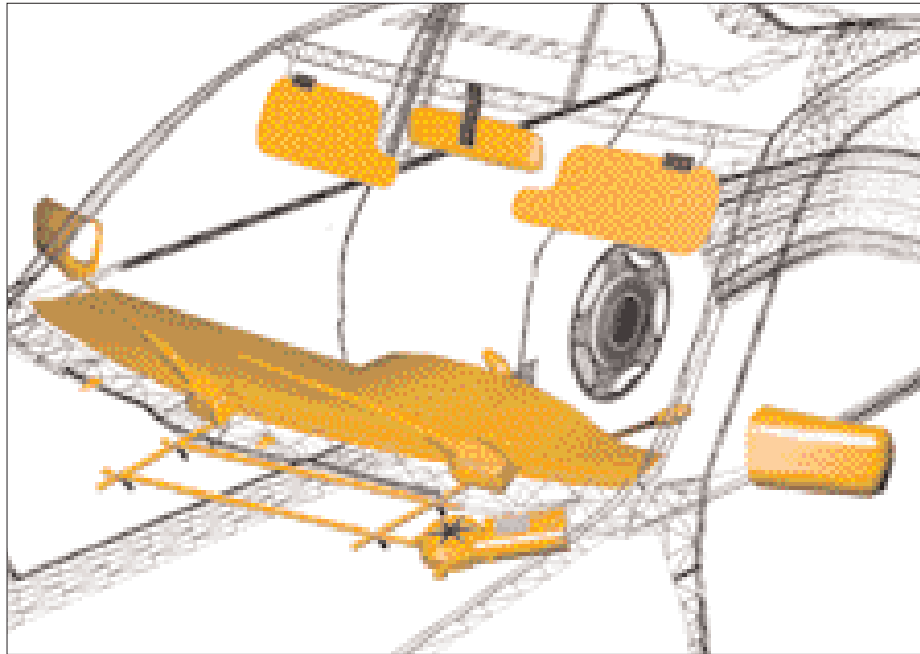

---

## Klüber products

*in alphabetical order*

---

CONSTANT GLY 2100, CONSTANT OY-series, DUOTEMPI PMY 45, ISOFLEX LDS 18 Special A, ISOFLEX TOPAS L 32/N, ISOFLEX TOPAS NB 52, Klüberalfa K 83-735, Klüberlectric KR 44-22, Klüberlectric KR 44-102, Klüberlectric KR 44-402, Klübersynth LR 44-21, Klübersynth LI 44-22, MIKROZELLA-series, NOXLUB-series, POLYLUB GLY 801, 501, 151

## Product approvals / specifications

*in alphabetical order*

Chrysler MS 9958, DBL 6827.40, Ford WSB-M1C160-D2, Ford WSD-M1C244-A, Ford WSD-M1C234-A2, Opel B 0400858, Opel B 0401122, Opel B 0401138, Opel B 0400882, Porsche 999.917.790.00, Porsche 999.917.791.00, PSA B 71 3841, VW-TL 778, VW-TL 778 A, VW-TL 778 B, VW-TL 751, VW-TL 52147

## Customers

*in alphabetical order*

Audi, BMW, Bosch, Britax, DaimlerChrysler, Fico Cables, Ford, Grammer, Hella, Kostal, Magna, NMB, NSK, Opel, PSA, Siemens VDO, Valeo, VW

*Please note that the a.m. information is only a small extract from our range of products and applications.*

# Locks and hinges

## Components

Bowden cables,  
central locking mechanisms,  
door check arms, hinges,  
latches, lock, catch bolts,  
locking pawls

## Lubricant requirements

Good low-temperature properties  
Resistance to water and de-icers  
Corrosion protection  
Lifetime lubrication  
Compatibility with paints

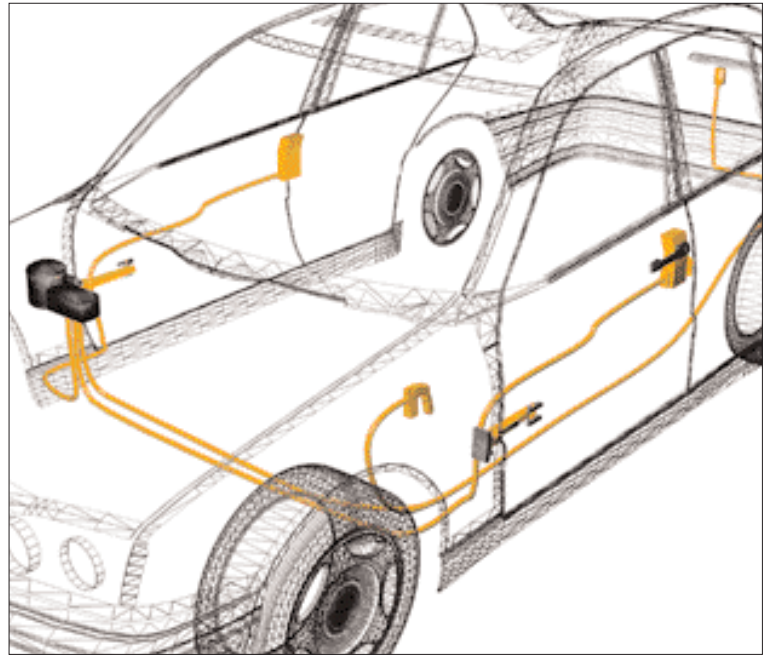

---

## Klüber products

*in alphabetical order*

---

CENTOPLEX 1 DL, ISOFLEX LDS 18 Special A, ISOFLEX TOPAS L 32/N, ISOFLEX TOPAS NB 152,  
Klüberalfa IR 83-22, Klübersynth LI 44-22, Klübertop TM 06-111, STABUTHERM GH 461,  
SYNTHESO GLEP 1, UNISILKON GLK 112

## Product approvals / specifications

*in alphabetical order*

Chrysler MS 9958, DBL 6827.40, Ford ESF-M1C-43-A2,  
Ford WSB-M1C160-D2, Ford WSD-M1C234-A,  
Ford WSD-M1C234-A2, Ford WSD-M1C238-A, Opel B 0400858,  
Opel B 0401122, Opel B 0400571, Opel B 0400852,  
Porsche 999.917.790.00, Porsche 999.917.544.00,  
PSA B 71 3841, VW-TL 778, VW-TL 778A, VW-TL 778B,  
VW-TL 767X, VW-TL 52141, VW-TL 52150

## Customers

*in alphabetical order*

Arvin Meritor, Audi, BMW, DaimlerChrysler, Edscha, Ford,  
Gammastamp, General Motors, Huf, Kiekert, Magna/Intier,  
MGI Coutier, Opel, Strattec, Valeo, VW, Witte

*Please note that the a.m. information is only a small extract from our range of products and applications.*

# Window lifters and sun roofs

## Components

Bowden cables  
Electric motors  
Sliding surfaces  
Small gears  
Toothed segments

## Lubricant requirements

Low noise level  
Good low-temperature properties  
Compatibility with plastics  
and elastomers  
Surface adhesion  
Dampening properties

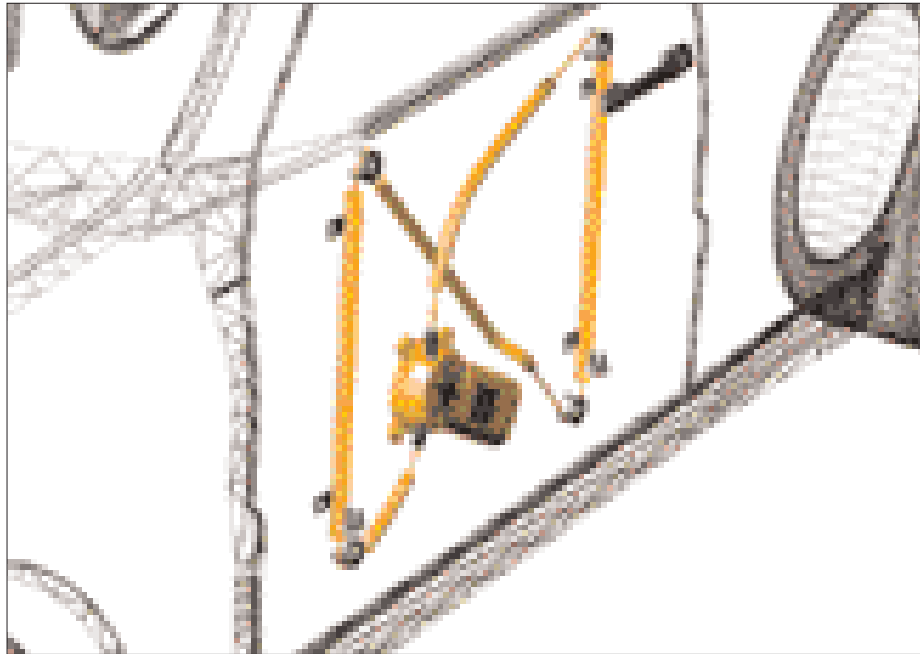

---

## Klüber products

*in alphabetical order*

---

ISOFLEX TOPAS L 32/N, Klüberlub EM 41-142, Klüberlub LM 41-32N, Klübersynth LF 44-22, Klübersynth LI 44-22, Klübersynth LR 44-21, POLYLUB GLY 151, POLYLUB GLY 501, POLYLUB GLY 801, UNISILKON GLK 112

## Product approvals / specifications

*in alphabetical order*

Chrysler MS 9958, DBL 6827.40, Ford ESF-M1C-43-A2, Ford WSB-M1C160-D2, Ford WSD-M1C244-A, Ford WSD-M1C234-A2, Opel B 0400858, Opel B 0400571, Opel B 0401138, PSA B 71 3841, VW-TL 778 A, VW-TL 778 B, VW-TL 767X, VW-TL 52147

## Customers

*in alphabetical order*

Arvin Meritor, Audi, Bosch, Bouverat, Brose, DaimlerChrysler, Ford, General Motors, IMS Gear, Jideco, Johnson Electric, Nuova SME, Lames, PRS, Saab, Siemens VDO, Unus, VW, Webasto

*Please note that the a.m. information is only a small extract from our range of products and applications.*

# Seats and seat belts

## Components

Adjusting units, buckles, electric motors, flexible shafts, retractors, retractor springs, screw spindles, seat rails, small gears, toothed segments

## Lubricant requirements

Lifetime lubrication  
Wide temperature range  
Low breakaway torque  
Good dampening properties  
Surface adhesion  
Paintability  
Emergency lubricating properties

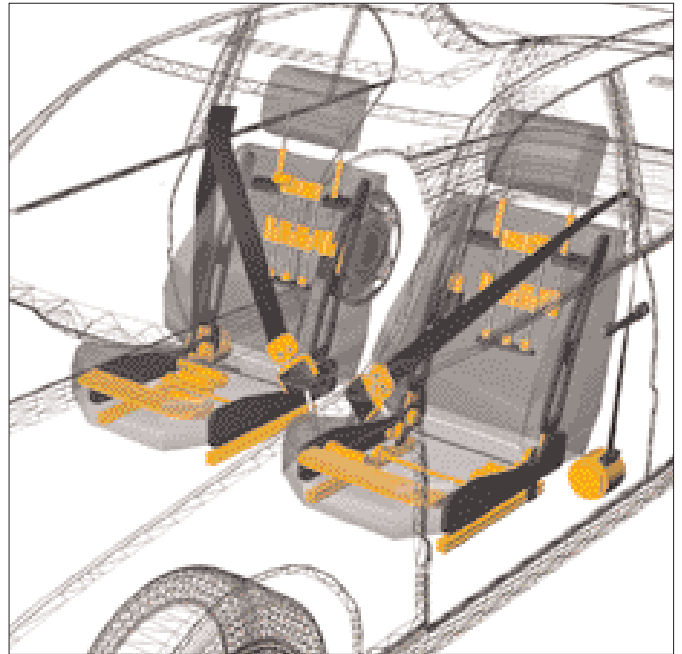

---

## Klüber products

*in alphabetical order*

---

CENTOPLEX CX 3/350, ISOFLEX TOPAS L 32/N, ISOFLEX TOPAS NB 52, ISOFLEX TOPAS NB 5051, Klüberpaste UH1 84-201, Klübersynth LF 44-22, Klübersynth LR 44-21, Klübertop TP 02-131, Klübertop TP 03-111, POLYLUB GLY 801

## Product approvals / specifications

*in alphabetical order*

Chrysler MS 9958, DBL 6827.40, Ford WSB-M1C160-D2, Ford WSD-M1C244-A, Ford WSS-M99C123-A, Opel B 0400858, Opel B 0401138, VW-TL 778 A, VW-TL 52147

## Customers

*in alphabetical order*

Audi, Autoliv, BMW, Brose, DaimlerChrysler, Faurecia, Ford, General Motors, Grammer, Hammerstein, Johnson Controls, Keiper, Kern & Liebers, Lear Seating, Magna Seating, Sitech, TRW, VW

*Please note that the a.m. information is only a small extract from our range of products and applications.*

# Bonded coatings for car body seals

## Components

Car body seals  
Door seals  
Folding top seals  
Sun roof seals  
Window channels and guides

## Lubricant requirements

Minimization of wear  
Improving wear protection  
Protection against stick-slip and noise  
Resistance to solvents and cleaning agents  
Noise reduction  
Antistick effect  
Assembly aid

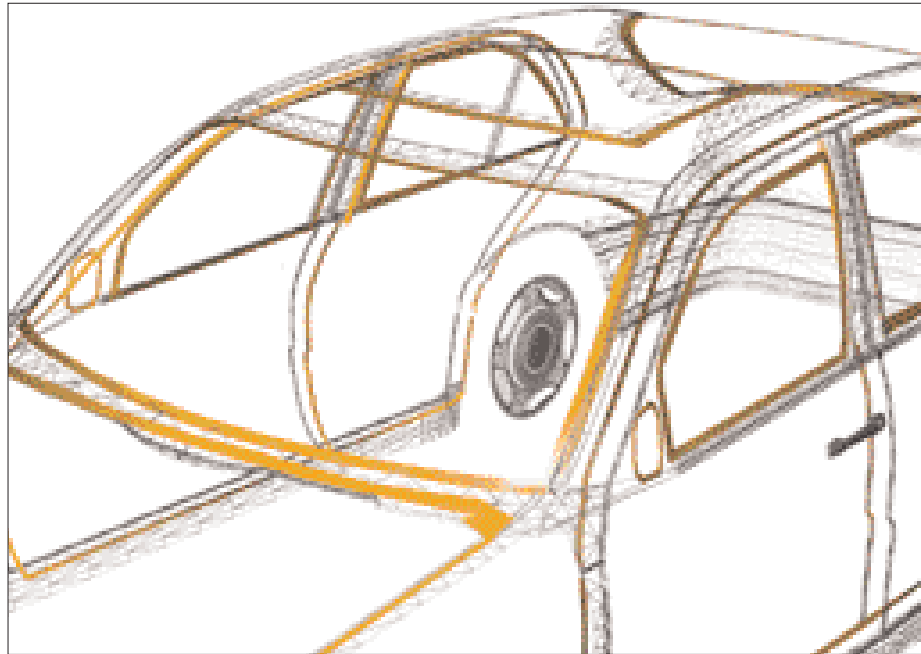

---

## Klüber products

*in alphabetical order*

---

Klübertop TP 18-810, Klübertop TP 22-1310 A/B, Klübertop TP 28-1310 LC A/B,  
Klübertop TP 28-1311 LC, Klübertop TP 29-1310 A/B, Klübertop TP 37-1310 A/B

## References

*in alphabetical order*

Audi, BMW, DaimlerChrysler, Fiat, Ford, Jaguar, Nissan,  
Opel, Peugeot, Renault, SAAB, Seat, Skoda,  
Suzuki, Toyota, Volvo, VW

## Customers

*in alphabetical order*

BSTG, CooperStandard, ContiTech Profile,  
Empire, GDX, GTG Gummitechnik,  
Hutchinson, Ilpea, Meteor Gummiwerke,  
Metzeler Automotive Profiles, Poppe,  
Veritas, Vorwerk

*Please note that the a.m. information is only a small extract from our range of products and applications.*

## Test rigs

### Top quality continuously monitored

As a supplier of special lubricants to the automotive sector, we treat quality assurance as a top priority.

Besides the chemical and physical specifications, technical performance is most important in our products. For this reason we run a variety of different test configurations to assess the load-bearing capacities of Klüber special lubricants.

However, standardized test methods are not sufficient. We want more: especially the highly complex applications found in motor vehicles tend to make the development of custom-made test rigs a necessity. Our team of engineers accomplishes this application-oriented task effectively and in close cooperation with the customer.

Ask us how we can help you to further increase efficiency by defining an optimised testing method.



*Klüber Bowden cable test rig*

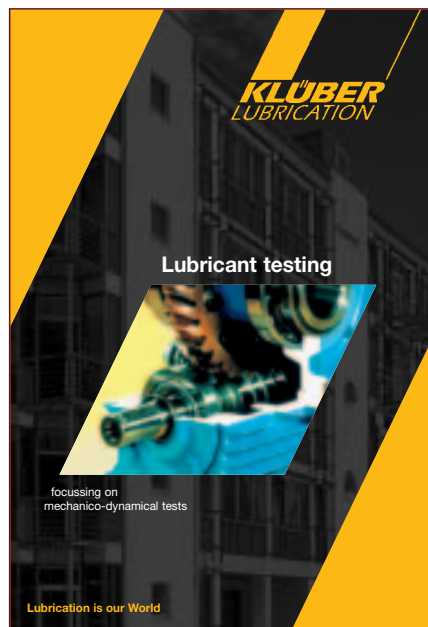

*Please ask for our Technical Publication "Lubricant testing", which is available in German, English, French, Spanish.*

# Test rigs



*CV-joint test rig  
Determination of  
service life*

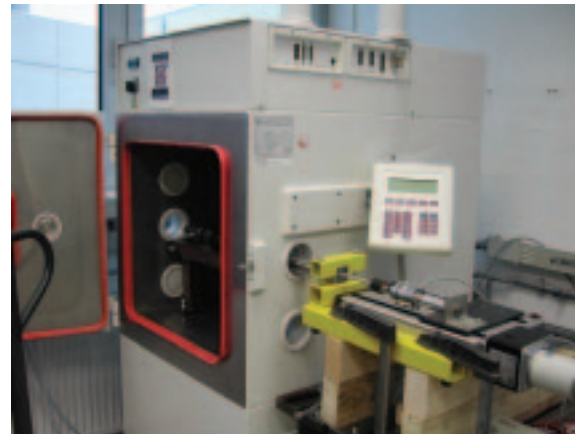

*Hot/cold chamber  
for individual tests*

*Test rig for clutch  
master/slave cylinder  
Recording creaking and  
squeaking noises*



*Test rig for electric contacts  
Determination of service life  
by measuring the electric  
resistance*

# Dry Lubrication

## Dry Lubrication

Bonded coatings ensure dry and clean lubrication of metal, plastic and elastomer parts. Apart from profiled seals and elastomers, bonded coatings are used also for small but important components like plain bearings, seat belt components, door locks, screws, pistons and many more.

### Klüber bonded coatings

- improve running-in behavior, also in connection with oil or grease lubrication
- protect against wear and avoid stick-slip at low speeds
- protect against corrosion
- provide lifetime lubrication
- facilitate assembly and disassembly of close-tolerance components

### Klüber bonded coatings for elastomers

- reduce friction to a minimum
- solve noise problems
- good haptics due to soft feel effect
- reduce assembly forces of O-rings
- increase wear resistance of seals

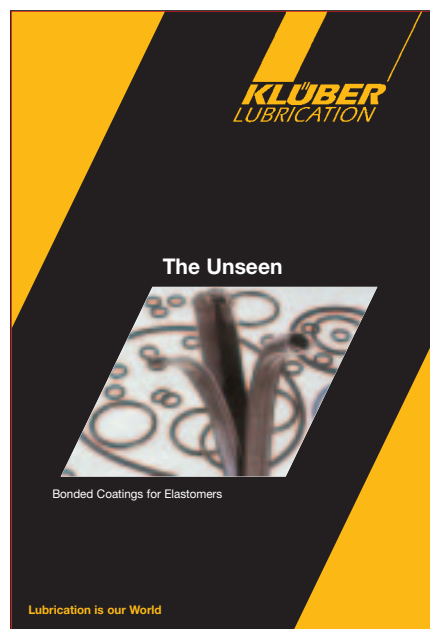
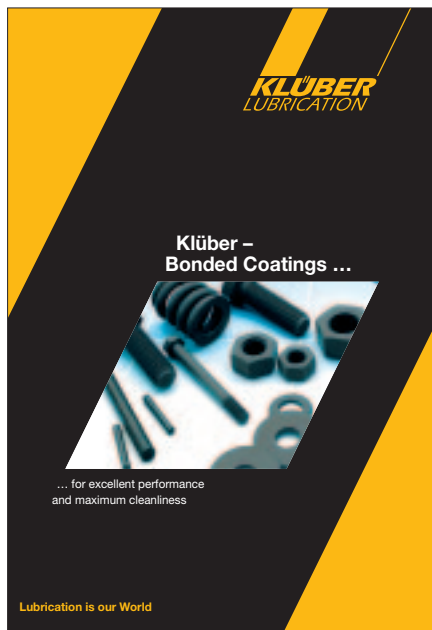

# Special containers and packing units

## Our service for you

You need a different pack size or your own container design? Whatever you wish for, Klüber will develop your specific packing unit.

Just tell us what your expectations of a perfect package are, what size would optimally fit in your stock of spare parts or which packing unit is your favorite. We will do it for you.



*Retail packing units designed for customers and special pack sizes – all filled with original Klüber products.*

# Klüber – all over the world

## Your pole position for success

Whether special lubricating greases or bonded coatings – experience what the world of lubrication has to offer. And this means not only in Germany. Wherever you need us, we will be there: we have over 27 subsidiaries in Europe, America, Asia, Australia and Africa, and more than 14 production sites around the globe.

Whether in Munich or Tokyo, a Klüber team of highly specialized experts is waiting for you. Advanced logistics and data systems ensure that the latest developments, experience and know-how can be exchanged reliably and fast world-wide. To help you make competitors see your taillights, we develop the lubricants of tomorrow today.

Klüber Lubrication – your partner for innovative lubricants. Contact us!

## Klüber worldwide



---

The data in this technical brochure is based on our general experience and knowledge at the time of printing and is intended to give information of possible applications to a reader with technical experience. It does not release the user from the obligation of performing preliminary tests with the selected product. We recommend contacting our Technical Consulting Staff to discuss your specific application. If required and possible we will be pleased to provide a sample for testing.

The lists of products and customer specifications are in straight alphabetical order; there is no direct reference between individual products and specifications listed.

Publisher and Copyright:  
Klüber Lubrication München KG

Reprints, total or in part, are permitted if source is indicated and voucher copy is forwarded.

9.24 e  
edition 06.04

